

**BUILT-IN SELF CLEANING
OVEN - MICROWAVE INSERTABLE
USE AND CARE MANUAL**

**Copy Your Model and Serial Numbers
IN THE BOX BELOW**

Model and Serial numbers are on a plate on the front frame behind the oven door. If you call for service, or with a question, have this information ready.

Keep this book, your installation guide, your warranty and the sales slip together.

Model No _____

Serial No _____

Purchase Date _____

Part No 338974

SAFETY RULES 3-4

HOW TO USE YOUR OVEN

• Clock and Oven Controls 5-6
• Oven Light 7
• Rack and Pan Arrangement 7
• Oven Vent 7
• Moisture 7
• New Oven Odor 7
• Preheating 7

COOKING HINTS 8-9

• Using Foil 8
• Choosing Oven Cookware 8
• Common Baking Problems and Causes 8
• Broiling Tips 9
• Positioning Broiler Pan 9

CLEANING AND CARE 10-14

• Oven Cleaning 10,11
• Cleaning Instructions 12
• Removable Oven Racks and Guides 12
• Removable Oven Door 13
• Replacing the Microwave Oven Fuse 14
• Replacing the Oven Light 15

PREVENTING SERVICE CALLS 14,15

L.P. BURNER ADJUSTMENTS

The adjustments in your Installation Guide must be made before you try to use your oven.

If you are using Liquified Petroleum Gas (bottled gas) all L.P. adjustments in your installation guide must be made before use.

If your oven is not properly adjusted, flames may be too high, or the range may use too much fuel, release toxic fumes or cook poorly.

FOR YOUR SAFETY

- If you smell gas:
1. Open windows.
2. Don't touch electrical switches.
3. Put out any open flame.
4. Call your gas supplier at once.

FOR YOUR SAFETY

Do not store or use gasoline or other flammable vapors and liquids near this or any other appliance.

IMPORTANT INSTRUCTIONS

Read the Safety Rules below and all operating instructions before using this appliance.

GENERAL

Keep this manual for further use.

Be sure your oven is properly installed and grounded by a qualified technician.

Never try to repair or replace any part of the oven unless specifically recommended in this manual. All other servicing should be done by a qualified technician.

Never block the flow of ventilation air. Always keep oven vent ducts open for free air flow. The oven vent duct is below the control panel.

PROTECT YOUR CHILDREN

Teach your children not to play with oven controls. As they become old enough, teach them to use the oven safely and correctly.

Never leave children alone or unwatched in an area where an oven is in use. Children should never be allowed to sit or stand on the open oven door. Never leave the oven door open when the oven is unattended.

SAFETY

Never use your oven for warming or heating a room. Such use can be dangerous as well as damaging to oven parts.

Never wear loose fitting or hanging clothes while using your oven. Such clothes may catch fire and cause serious injury.

Never heat unopened food containers. Pressure build-up may make container burst and cause injury.

Always use care when opening oven door. Let hot air or steam escape before removing or replacing food.

Always move oven racks while oven is cool. If a rack must be moved while the oven is hot, do not let the pot holder touch the hot heating element in the oven.

Always use dry pot holders when removing pans from the oven. Moist or damp pot holders can cause steam burns. Do not let a pot holder touch a hot heating element. Do not use a towel or other bulky cloth.

Never touch oven heating elements or interior surfaces of the oven. Heating elements and nearby areas may be hot enough to burn you even though they are dark in color. During and after use, do not let clothing or flammable materials touch heating elements or oven surfaces until they have had time to cool. Other surfaces that may become hot during use are the oven vent door and the oven door.

GREASE FIRES

Always keep the appliance area clear and free from things that will burn, gasoline and other flammable vapors and liquids. Never store materials in an oven. Flammable items may catch fire and plastic items may melt and burn.

When broiling, always remember to remove the broiler pan from the oven and clean it when you are done cooking. If you leave a broiler pan full of grease in the oven and later use the oven, you may have a broiler fire.

Never use aluminum foil to line the oven bottom, except as suggested on page 8 of this manual. Improper use of these liners may create a fire hazard.

PUTTING OUT AN OVEN FIRE

If you do have an oven fire, do not try to move the pan. Instead:

1. Keep oven door closed.
2. Turn oven off.
3. If the fire continues, throw baking soda on the fire.

Never use water on a grease fire — it will only spread the flames. Never pick up a flaming pan.

SELF-CLEANING OVEN

Always remove the oven racks, the broiler pan and other utensils before a self-cleaning cycle.

Never use any type of commercial oven cleaner or oven liner protective coating in or around any part of your oven. Do not use any type of aerosol product near your oven because the chemical that produces the spraying action, may, in the presence of heat, cause metal parts to corrode and could be flammable.

The door gasket is essential for a good seal so care should be taken not to rub, damage, or move the gasket. Clean only with hydrogen peroxide. See page 10.

Clean only oven parts listed in this manual. See pages 10-13 for special cleaning instructions.

CLOCK AND OVEN CONTROLS

The lower oven is entirely controlled by the Electronic Range Control. Follow instructions below.



TO SET THE CLOCK:

1. Push CLOCK button.
2. Turn SET knob to correct time of day. Clock is now set.

Note: To display the time of day during timed baking, push the CLOCK button. This will show the time but will not cancel any oven operation.

TO SET THE TIMER:

1. Push TIMER button.
2. Turn SET knob to desired amount of time. The Timer will immediately begin to count down.
3. When time is up, the end of cycle tone will sound.
4. To cancel the Timer, push and hold TIMER button for three seconds. This will clear the TIMER function. If the "Timer time" was being displayed, the display will go to the time of day. If the "Timer time" was not being displayed, the display will not change.

Note: The Timer is a reminder only and will not operate the oven. You can use the Timer whether or not the oven is being used. The Timer does not interfere with oven operations.

TO BAKE:

1. Push BAKE button.

2. Turn SET knob until desired temperature is displayed. The oven begins to heat within two seconds, and the display will show the temperature as it rises (in 5°F steps).
3. The Notification Tone will sound when the oven has stabilized at the selected temperature. The display will show this temperature before the tone.

Note: To recall what temperature you have selected while the rising temperature is being shown, push and hold the BAKE button. The selected temperature will be shown while you hold the BAKE button and will return to actual oven temperature when you release the BAKE button. You can change the selected temperature at any time by pushing the BAKE button and turning the SET knob.

TO BROIL:

1. Push BROIL button.
2. Turn SET knob to HI or LO Broil (see page 9).
3. When finished broiling, push the OVEN CANCEL button.

TO USE TIMED OVEN/DELAY START

Put the food in the oven and program your Electronic Range Control to turn the oven on and off. Follow instructions below and on next page.

CAUTION

Never let food sit for more than 4 hours before cooking starts, when you set your oven for a delay start. Room temperature is ideal for the growth of harmful bacteria. Be sure oven light is off because heat from the bulb will speed bacteria growth.

- Note:** To cancel any timed oven operation, push the OVEN CANCEL button.

TO START NOW AND STOP LATER:

1. Push COOK TIME button
2. Set length of baking time with SET knob
3. Push BAKE button
4. Set desired temperature with SET knob
5. When COOK TIME is reached, the end of cycle tone will sound and the oven will turn off.

Note: You can push the STOP TIME button to find out when the end of cycle will sound and the oven will turn off.

TO START LATER AND STOP LATER:

1. Push COOK TIME button
2. Set length of baking time with SET knob
3. Push STOP TIME button
4. Set time of day when baking should be completed with SET knob
5. Push BAKE button
6. Set desired temperature with SET knob
7. When STOP TIME is reached, the end of cycle tone will sound and the oven will turn off.

Note: You can push the STOP TIME button to find out when the oven will turn off. Push and hold the COOK TIME button to find out when the oven will turn on.

When a function has been entered, you can recall what has been programmed by pushing the corresponding function button. The messages in the display show you which function is currently being displayed. While the function is displayed, you can change it with the SET knob. You can change any programmed function at any time.

TONES

End of Cycle Tone (3 long beeps - one second on, one second off) shows that a timed oven operation has reached STOP TIME or that the Timer has counted down.

Attention Tone (series of short beeps, one quarter second on, one quarter second off, until proper response is given) will sound if oven has only been partially programmed. For example, if you have selected a COOK TIME but no temperature, you will hear the attention tone until you select a temperature or push OVEN CANCEL.

Notification Tone (single, one second beep) shows that the oven has stabilized at the selected temperature.

Keytone (single, one tenth second beep) sounds when any button is pushed.

Failure Tone (series of very rapid beeps, one eighth second on, one quarter second off) display will show F0-F8. Cancel failure tone by pushing the OVEN CANCEL button. If the failure occurred while you were programming the Electric Range Control, push the OVEN CANCEL button and try again. If you still get a failure tone that does not stop after 16 seconds, call for service. If you are unable to cancel the failure tone with the OVEN CANCEL button, unplug the range or disconnect the circuit breaker.

If you prefer that your range not have an audible tone at the end of a cycle or when you push a button (Key Tone), you can eliminate the End of Cycle and Key Tone by pushing and holding the OVEN CANCEL button until you hear a short beep (in approximately two seconds). If you wish to activate the tones again, push and hold the OVEN CANCEL button once more until you hear a short beep. Cancelling or activating the tones should only be done when there is no oven operation programmed. Pushing the OVEN CANCEL button will clear all functions except the clock and Timer.

OVEN LIGHT

The switch on the control panel turns the oven light on and off. See page 15 for more information.

RACK AND PAN ARRANGEMENT

Put oven rack(s) in place before turning on the oven. Rack positions are numbered starting at the bottom with number 1. In general, when using only one rack in the lower oven, position No. 2 should be used. When using two racks, positions No. 2 and 4 work best.

Pans too close to each other, to oven walls or to the oven bottom block the free movement of air. Improper air movement causes uneven browning and cooking.

Normally there should be 1½ to 2 inches of air space on all sides of each pan in the oven. See tips below.

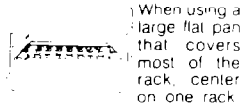

When using a large flat pan that covers most of the rack, center on one rack.

Sheet Cake, Cookies, Biscuits

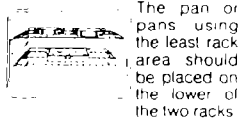

The pan or pans using the least rack area should be placed on the lower of the two racks.

Cake Layers, Pies, Casseroles, 3 Pans

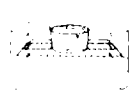

When baking a sponge or angel food cake, center on one rack in the lowest position.

Angel Food or Sponge Cake



When using two racks and several pans, stagger them so no pan is directly above another.

Cake Layers, Pies, 4 Pans (staggered)

OVEN VENT

When the oven is on, air moves through a vent below the control panel. This hot air may make controls hot.

The vent is needed for proper air flow in the oven and good baking results. Do not block this vent. Doing so may cause cooking failure, fire and damage to the range.

MOISTURE

As your oven heats up, water droplets may form on the door or door glass. To prevent this, open the oven door for the first minute of oven heat up to let the moist air out.

NEW OVEN ODOR

During the first baking and broiling cycles on your new oven, there may be some odor. This is normal and is caused by the heating of new parts and insulation. The odor will go away within a short time. A vent fan or other ventilation will help to clear the air.

PREHEATING

Preheating lets the oven heat evenly before the food is put in. Allow 10 minutes at temperature less than 350°F and about 15 minutes at temperatures at 350°F or more.

With recipes that call for an oven preheated to a certain temperature, it is very important that you follow those instructions. It is not likely that you will get good baking results every time without preheating to the needed temperature, unless the recipe says to start in a cold oven.

After the oven is preheated and you are ready to put the food in, try to have everything handy so that you will not have to leave the oven door open for an extended period of time.

Opening the door to check the food during baking makes it impossible for the oven to stay at the temperature you have selected. Try to time your baking and check only when close to being finished.

NOTE: When using cookware made of ovenproof glass or pottery, Teflon coated cookware or dull or darkened pans in the oven, be sure to reduce recipe temperature by 25°F (see Choosing Cookware page 8).

USING FOIL

For Baking

To catch spills, cut a piece of foil slightly larger than the pan and turn up the edges. Use two oven racks and put the foil on the lower oven rack below the pan. Do not use aluminum foil directly under a pan on the same oven rack. The foil will reflect heat away from the pan.



Do not cover the oven bottom or an entire oven rack with foil. The foil can block normal heat flow, cause cooking failures, and damage the oven interior.

For Roasting

For slow browning, place a foil "tent" loosely over the meat. This is especially good on a large turkey. The "tent" lets oven heat circulate under the foil. Sealing the foil will tend to steam the meat.

To reduce spattering, lightly crush foil and put it in the bottom of the pan under the food.

For Broiling



Do not cover the entire broiler grid with foil. Poor drainage of hot fat may cause a broiler fire. If a fire starts, close the oven door and turn controls off. If fire continues, throw baking soda on the fire. Do not put water on the fire.

CHOOSING OVEN COOKWARE

ALUMINUM: Absorbs heat faster than glass or steel and conducts heat well. Gives delicate browning, tender crusts, and reduces spattering of roasts. Best for cakes, muffins, quick breads, cookies and roasting.

OVENPROOF GLASS/POTTERY: Because this cookware absorbs and holds heat well, you should lower your oven temperature 25°F. Gives a food a deep, crusty brown top. Best for casseroles.

TEFLON® , DULL OR DARKENED COOKWARE: Absorbs heat quicker than shiny cookware. Lower your oven temperature 25°F (except for pastry). Good for pies and other foods baked in pastry shells.

COMMON BAKING PROBLEMS AND CAUSES

CAKE RISES UNEVENLY

- Range or oven rack not level
- Pan warped
- Batter spread unevenly in pan
- Pan too close to oven wall or rack to crowded

CAKE HIGH IN MIDDLE

- Too much flour
- Oven temperature too high

CAKE NOT DONE IN CENTER

- Wrong pan size
- Oven too hot
- Pan not centered in oven

CAKE FALLS

- Too much shortening, liquid or sugar
- Temperature too low
- Pan too small
- Oven door opened too often
- Too much leavening or stale leavening
- Overmixing after adding flour

BOTTOM PIE CRUST

SOGGY

- Filling too juicy
- Filling allowed to stand in pie shell before baking
- Used shiny pans
- Temperature too low at start of baking
- Crust and/or filling not allowed to cool before filling crust

BURNING AROUND EDGES OF PIE CRUST

- Oven temperature too high
- Edges of crust too thin or too high
- Oven too full or pans too close together

COOKIES AND BISCUITS BURN ON BOTTOM

- Oven preheat time too short
- Pan too deep or too large
- Used dark pans
- Used wrong rack position

FOOD NOT DONE AT END OF COOKING TIME

- Oven temperature set too low
- Oven too crowded
- Oven door opened too often
- Aluminum foil blocking air movement

BROILING TIPS

- Your oven door should be open to the stop position while broiling. If the door is closed the food will roast instead of broil (see page 13).
- Use only the broiler pan and grid furnished with your range for broiling. They are designed for proper drainage of fat and liquids and help prevent spatter, smoke or fire.
- **Do not preheat** when broiling. For even broiling on both sides, broil the food on a cold pan. Allow slightly more than half the cooking time for the first side then turn the food using tongs. If you pierce the meat with a fork, the juices will escape.
- **When broiling frozen meat**, use one rack position lower than recommended up to 1½ times the suggested broiling time.
- Trim the outer layer of fat from steaks and chops. Silt the fatty edges to keep the meat from curling.
- Always put the food being broiled on the proper rack. (see chart at right.) Food placed too close to the broiler may spatter, smoke or catch fire.
- For maximum juiciness, salt the first side just before turning the meat. Salt the second side just before serving.
- Brush chicken and fish with butter several times as they broil. When broiling fish, grease the grid to prevent sticking.
- **Never leave a soiled broiler pan in the range.** Grease in the pan may smoke or ignite the next time oven is used. See page 12 for tips on cleaning the broiler pan and grid.
- **Be sure you know the correct procedure** for putting out a grease fire. See Page 4.

POSITIONING BROILER PAN

Broiling is cooking by direct heat from the upper oven element. Tender cuts of meat or marinated meat should be selected for broiling. For best results steaks and chops should be at least ¾" thick. After placing food on the broiler pan, put the pan on an oven rack in the proper position. The recommended rack position and cooking time can be found in the chart below. Most foods can be broiled on the HI setting. Select the LO broil setting to avoid excessive browning or drying of foods that should be cooked to the well done stage (such as thick pork chops or poultry). The closer the food is to the broil element the faster the meat browns on the outside, yet stays red to pink in the center. Moving the meat farther away from the element lets the meat cook to the center while browning outside.

FOOD	RACK POSITION 4 = HIGHEST 1 = LOWEST	TOTAL TIME (MINUTES)
Steak - 1" Thick		
Rare	4	10-12
Medium	3	14-16
Well Done	3	20-22
Ground Beef Patties		
Medium	3	11-13
Well Done	3	13-15
Lamb Chops - 1" Thick	3	16-20
Pork Chops - 1" Thick	3	20-25
Pork Shoulder Steaks	3	15-20
Ham Slice - 1" Thick	3	14-16
Fish (Filets)	3	10-15
Chicken (Halves)	1	40-60
Frankfurters	3	10-15
Bacon	3	5-7
Open-face Sandwiches	2	6-10

This chart is a general guide. The size, weight, thickness and starting temperature of the food, as well as your own personal preference, will effect the desired cooking.

THE SELF-CLEAN CYCLE

- 1 Remove the broil pan and grid, oven racks, all utensils and any foil that may be in the oven. If oven racks are left in the range during a clean cycle, they will darken, lose their luster and become hard to slide.
- 2 Soil on the oven front frame, under the front edge of the cooktop, the door liner outside the door seal and the front edge of the oven cavity (about 1" into the oven) will not be cleaned during a clean cycle (see illustration below). Clean these areas by hand before starting a clean cycle.

Use detergent and hot water with a soap-filled steel wool pad, then rinse well with a vinegar and water mixture. This will help prevent a brown residue from forming when the oven is heated.

Before A Clean Cycle

- 3 Wipe up heavy spillovers on the oven bottom. Too much soil may cause smoking during the clean cycle.
- 4 Clean the door seal by using a clean sponge to soak the soiled area with hydrogen peroxide. Repeated soaking may be needed depending on the amount of soil. Frequent cleaning will prevent excessive soil build up. Do not rub the door seal excessively. The fiberglass material of the seal has an extremely low resistance to abrasion. Any cotton material especially (including cottonballs), can easily rub a hole into the seal. Do not use any cotton materials to clean the seal. An intact and well fitting oven door seal is essential for energy efficient oven operation and good baking results. If you notice the seal becoming worn, frayed or damaged in any way or if it has become displaced on the door you should replace the seal.

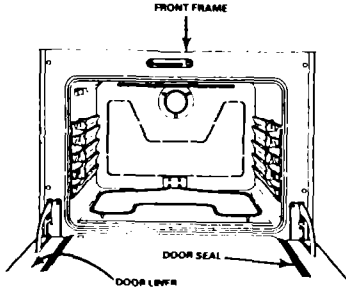

DO NOT use commercial oven cleaners or oven protectors in or near the oven. These products plus the high temperature of the clean cycle may damage the porcelain finish.

DO NOT clean glass ceramic cookware or any other cookware in the oven during a self clean cycle.

IMPORTANT INFORMATION

All controls must be set correctly for the clean cycle to work properly. To help you understand how the clean cycle works, the stages of the cycle are noted below.

1. The controls are set.
2. The word CLEAN will be on in the display, the oven begins to heat and the door locks automatically.
3. For your safety the oven door can not be opened (the word LOCK will be on in the Electronic Range Control display.)
4. When the 3 1/2 hour clean cycle is over the word CLEAN will be off in the display the oven begins to cool.
5. When the temperature has fallen below locking temperature the door can be opened (the word LOCK will be off in the display).

After a cleaning cycle, the oven door cannot be unlocked unless the temperature has had time to drop to a safe level and the word LOCK is off in the Electronic Range Control display.

TO SET A CLEAN CYCLE

The self-cleaning cycle is preprogrammed for 3½ hours. You can also set the electronic range control for a delayed start of the clean cycle.



To self-clean:

- 1 Push the CLEAN button.
- 2 Turn SET knob in the clockwise direction about ½ turn.

The word CLEAN will be on in the display.

NOTE: You can find out when the clean cycle will be finished by pushing the STOP TIME button.

To use delayed self-clean:

- 1 Push STOP TIME button.
- 2 Turn SET knob to time of day when you wish cleaning to be completed (must be more than 3½ hours later than current time of day).
- 3 Push the CLEAN button.
- 4 Turn SET knob in the clockwise direction about ½ turn.

The words DELAY CLEAN will be on in the display until the clean cycle starts. After the clean cycle starts, the word CLEAN will be on in the display.

Note: During a delayed self-clean operation you can find out when the oven turns on by pushing and holding the CLEAN button.

TO STOP A CLEAN CYCLE:

- 1 Press the OVEN CANCEL button.
- 2 Wait until the oven has cooled below locking temperature and the word LOCK is off in the display.

You will not be able to open the door unless the oven temperature is at a safe level. If you cannot open the oven door immediately after the word LOCK goes off, wait about one minute and try again.

WHEN A CLEAN CYCLE IS FINISHED

- 1 When a clean cycle is finished the word CLEAN will be off in the display.
- 2 Wait until the oven has cooled below locking temperature and the word LOCK is off in the display.

You will not be able to open the door unless the oven temperature is at a safe level. If you cannot open the oven door immediately after the word LOCK goes off, wait about one minute and try again.

AFTER A CLEAN CYCLE

After a clean cycle, you may notice some white ash in the oven. Just wipe it up with a damp cloth.

If white spots remain, remove them with a soap-filled steel wool pad. Be sure to rinse thoroughly with a vinegar and water mixture. These deposits are usually a salt residue that can not be removed by the clean cycle.

If the oven is not clean after one clean cycle, the cycle may be repeated.

CLEANING INSTRUCTIONS

CONTROL PANEL

Wash with soap and water, rinse then dry with a paper towel.

OVEN FINISHES

SELF-CLEANING Use soap, water and a scouring pad for touch up cleaning between self-cleaning cycles. Give a final rinse with vinegar and water. Avoid any contact with oven door seal (see below). Never use any oven cleaners.

OVEN RACKS: Remove from oven (see instructions on page 12) and wash at sink with soap, water and a scouring pad.

BROILER PAN AND GRID: Do not leave in range to cool. If you soak right away, clean-up will be easier. Remove pan from oven and remove fat and drippings. Sprinkle pan with detergent then cover with a wet cloth or paper towel and let soak. Later wash in soap and water using a scouring pad as necessary. Both the pan and the grid are dishwasher safe.

OUTSIDE FINISHES

CHROME: Wash with soap and water. A chrome cleaner may be used.

GLASS: Wash with a damp, soapy cloth. Remove stubborn soil with a paste of baking soda or ammonia and water. Do not use abrasive materials. Before using an all purpose cleaner, check the label to be sure it is recommended for glass—some will permanently damage glass.

REMOVABLE OVEN RACKS AND GUIDES

Be sure not to scratch the oven finish when installing or removing oven racks.

To install:

- 1 Put the pegs on the end of the rack guide into the holes in the oven back.
- 2 Lock the front hook in the slot in the oven side.
- 3 Set the raised back edge of the oven rack on a pair of rack guides so the hooks at the sides of the rack run underneath the rack guides.
- 4 Push the rack in until you reach the bump in the rack, then lift the front of the rack a bit and push the rack all the way in.

To remove:

- 1 Pull the oven rack out, then up, in one motion.
- 2 Lift the front of the rack guide to unhook it from the oven wall and pull out.

See the cleaning instructions on page 12.

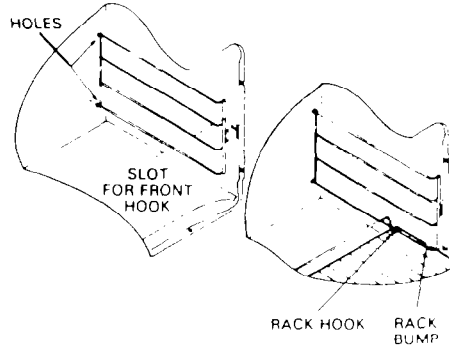

REMOVABLE OVEN DOOR

The oven doors can be removed for cleaning.

To remove:

1. Open the door to the broil stop position and grasp the door at each side (see illustration)
2. Lift the door up a bit, then pull straight toward you.

To replace:

1. Make sure that hinge arms are in position B (broil stop position).
Note: If a hinge arm snaps into position A, it must be moved back to position B before the door can be replaced.
2. Carefully insert the hinge arms through the openings in the front frame and push the door into place while holding the door up.
3. When the bottom edge of the door is flush against the front frame, allow the door to settle into place.

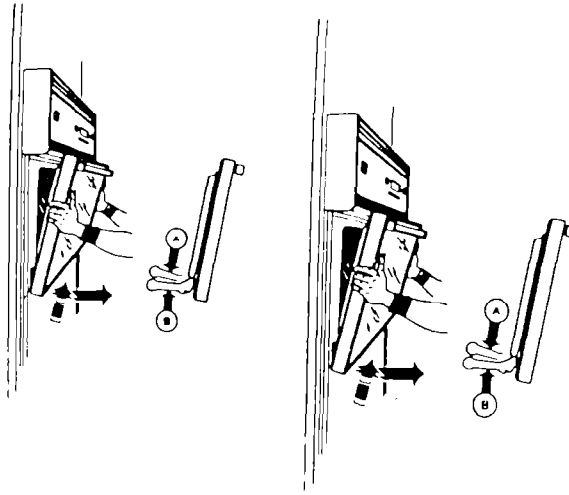

Cleaning and Care

REPLACING THE MICROWAVE OVEN FUSE

Below the microwave oven there is a fuse to protect the microwave oven from malfunctions in the electrical system or components.

If your lower oven works but your microwave oven will not work:

1. Check your microwave oven manual to be sure you have followed operating instructions exactly.
2. Remove the two screws in the side trim and the two screws in the vent trim and remove the trim/vent box assembly.
3. If there is no adjacent counter or table, move a chair close to the oven. Remove the microwave oven and place it on a counter, table or chair.
4. Replace the old fuse with a 15 amp. type S fuse
5. Lift the microwave oven and slide back into place above the lower oven. Be careful not to pinch or damage the microwave oven cord on the back of the lower oven when sliding the microwave oven back into place.
6. Reposition the trim/vent box assembly and attach with screws previously removed.

If your microwave oven still will not work, or if it blows another fuse, call for service.

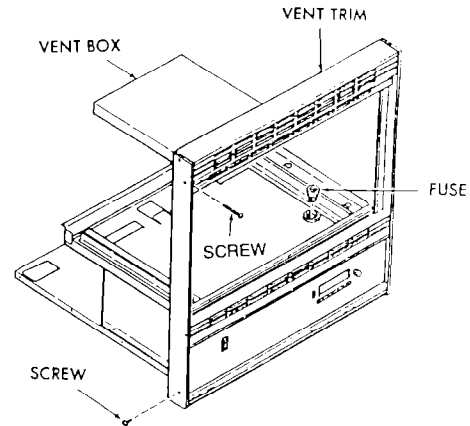

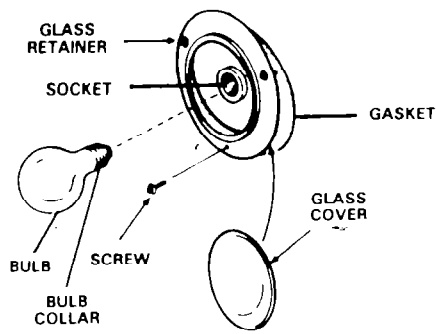

REPLACING THE OVEN LIGHT

Do not touch oven bulb when hot, with wet hands, or wipe oven light area with wet cloth. Unplug or disconnect the electrical supply to oven before removing.

Never touch the electrically live collar on the bulb when replacing it

Electrical power must be shut off if you have to replace a broken bulb:

- 1 Remove the three screws and lift off the glass retainer and glass cover
- 2 Replace the bulb with a 40 watt appliance bulb. An appliance bulb is smaller than a standard 40 watt household bulb.
- 3 Replace the gasket, glass cover and glass retainer. Tighten screws securely.

IF YOU HAVE A PROBLEM

Problems are often caused by little things that you can fix yourself without any tools. Make sure you are following instructions in this book and read the list of common problems and solutions on this and the next page.

If you have a problem you can't fix yourself, call your Roper Dealer for help.

CLOCK/TIMER DOES NOT WORK

- Check to be sure range cord is plugged into outlet completely. Check for blown fuse or tripped circuit breaker.
- Check for power outage.
- Check step by step operating instructions on pages 5 and 6.

OVEN LIGHT WILL NOT WORK

- Check to be sure range cord is plugged into outlet completely. Check for blown fuse or tripped circuit breaker.
- Check for power outage.
- Check for loose or burned out bulb. See page 15 for replacement instructions.

OVEN TEMPERATURE SEEMS INACCURATE

- Is proper airflow blocked by aluminum foil? See page 8 for tips on correct use of foil.
- Is the oven vent blocked? See page 7.
- Check the section on baking problems and causes on page 8.
- The oven thermostat on your new range may be more accurate than the one on your old range. See page 16 for information on adjusting the oven temperature.

OVEN/BROILER ELEMENT DOES NOT WORK

- Check for power outage. Check for blown fuse or tripped circuit breaker.
- Are controls set correctly? See pages 5 and 6.

RANGE IS BEEPING

- See the section on Tones, page 6.

BROILING PROBLEMS

- Oven Control knob not set to BROIL. See pages 5 and 6.
- Using wrong rack position. See chart on page 9.
- Aluminum foil not used properly and grease can't drain correctly. See page 8.

OVEN DOOR WILL NOT UNLOCK AFTER CLEANING

- The door will not unlock until the oven has cooled to a safe temperature. See page 11 for instructions on unlocking the door.

OVEN WILL NOT SELF-CLEAN

- Oven controls not set properly. Review step by step instructions on page 11.
- Heavy spillovers were not wiped up before starting clean cycle. See page 10.
- Oven too dirty — should be cleaned more often.

ADJUSTING OVEN TEMPERATURE

The temperature in your new range has been set correctly at the factory, so be sure to follow the recipe temperatures and times the first few times you bake in your new oven.

If you think the oven should be hotter or cooler, you can adjust it yourself. To decide how much to change the temperature, set the oven temperature 25°F higher or lower than the temperature in your recipe, then bake. The results of this "test" should give you an idea of how much the temperature should be changed.

To adjust temperature:

1. Push the **BAKE** button.
2. Select a temperature between 500°F and 550°F with the **SET** knob.
3. Quickly (within two seconds, before the **BAKE** function energizes) push and hold the **BAKE** button. The display will go blank and then will show the amount of degrees difference between the original factory temperature setting and the current temperature setting. If the oven temperature has never been adjusted the display will read 00.
4. The temperature can be adjusted up to 35°F hotter or 35°F cooler in 5°F steps. A minus sign (-) before the number means that the oven will be cooler by displayed amount of degrees.
5. When you have made the desired adjustment, push the **CLOCK** button to go back to the time of day display or use your oven as you would normally.

Note: The self-clean temperature will not change by the adjustment described above.